

# KORG

PERFORMANCE SIGNAL PROCESSOR

# A4

GUITAR

## OWNER'S MANUAL

CONNECTION WITH A GUITAR .....	3
PLAYING PRESET PROGRAMS [PROGRAM MODE] .....	4
OPERATING INDIVIDUAL EFFECTS [MANUAL/EDIT MODE] .....	5
CREATING ORIGINAL PROGRAMS [MANUAL/EDIT MODE] .....	6
SAVING EFFECT PROGRAMS [PROGRAM WRITE] .....	8
OTHER USEFUL FUNCTIONS .....	9
PROGRAM LIST .....	27

# IMPORTANT SAFETY INSTRUCTIONS

**WARNING** : When using electronic products, basic precautions should always be used. Including the following:

1. Read all the instructions before using the product.
2. To reduce the risk of injury, close supervision is necessary when a product is used near children.
3. Do not use this product near water—for example, near a bathtub, washbowl, kitchen sink, in a wet basement, near a swimming pool, etc.
4. This product, either alone or in combination with an amplifier and headphones or speakers, may be capable of producing sound levels that could cause permanent hearing loss. Do not operate for a long period of time at high volume levels or at a level that is uncomfortable. If you experience any hearing loss or ringing in the ears, consult an audiologist.
5. The product's location or position should not interfere with its proper ventilation.
6. The product should be kept away from heat sources such as radiators, heat registers, and other products that produce heat.
7. The product should be connected to a power supply only of the type described in the operating instructions or as marked on the product.
8. The unit's power cable should be unplugged from the outlet when left unused for a long period of time.
9. Care should be taken so that neither objects nor liquids fall into the unit's enclosure through its openings.
10. The product should be serviced by qualified service personnel when:
  - A. The power-supply cord or the plug has been damaged
  - B. Objects have fallen into, or liquid has been spilled into the product
  - C. The product has been exposed to rain
  - D. The product does not appear to operate normally, or exhibits a marked change in performance
  - E. The product has been dropped, or its enclosure damaged
11. Do not attempt procedures to service the product beyond those described in the user maintenance instructions. All other servicing should be referred to qualified service personnel.

Congratulations! And thank you for purchasing the KORG A4 Guitar Performance Signal Processor. To get the most out of this advanced instrument and enjoy it in its optimum condition for the longest possible time, please read this manual carefully and keep it handy for reference.

## TABLE OF CONTENTS

PRECAUTIONS FOR USE .....	1	2. Standard Pitch and Calibration .....	12
NAMES AND FUNCTIONS OF CONTROLS AND TERMINALS .....	2	3. Example of tuning .....	12
CONNECTION WITH A GUITAR .....	3	4. Tuning .....	12
PLAYING PRESET PROGRAMS [PROGRAM MODE] .....	4	EFFECT PARAMETER LIST .....	13
OPERATING INDIVIDUAL EFFECTS [EDIT MODE] .....	5	1. Compressor [COMPRESSOR] .....	13
CREATING ORIGINAL PROGRAMS [EDIT MODE] .....	6	2. Distortion/Overdrive [DIST/OD] .....	13
UTILITY .....	7	3. Three-Band Equalizer [3 BAND EQ] .....	14
SAVING EFFECTS PROGRAMS [PROGRAM WRITE] .....	8	4. Pitch/Delay [PITCH•DELAY] .....	14
OTHER USEFUL FUNCTIONS .....	9	5. Chorus/Flanger [CHORUS/FLANGER] .....	16
1. Comparison with Preset Data .....	9	6. Reverb [REVERB] .....	17
2. Using the Optional Volume Pedal .....	9	7. Utility .....	17
3. MIDI .....	10	ERROR MESSAGES .....	18
4. External Control .....	11	TROUBLESHOOTING .....	18
TUNER .....	12	MIDI IMPLEMENTATION .....	19
1. Bypass•Tune Switch .....	12	PROGRAM LIST .....	27
		SPECIFICATIONS AND OPTIONS .....	28

### THE FCC REGULATION WARNING

This equipment generates and uses radio frequency energy and if not installed and used properly, that is, in strict accordance with the manufacture's instructions, may cause interference to radio and television reception. It has been type tested and found to comply with the limits for a Class B computing device in accordance with the specifications in Subpart J of Part 15 of FCC Rules, which are designed to provide reasonable protection against such interference in a residential installation. If this equipment does cause interference to radio or television reception, which can be determined by turning the equipment off and on, the user is encouraged to try to correct the interference by one or more of the following measures:

Reorient the receiving antenna

Relocate the equipment with respect to the receiver  
Move the equipment away from the receiver  
Plug the equipment into a different outlet so that it and receiver are on different branch circuits.

If necessary, the user should consult the dealer or an experienced radio/television technician for additional suggestions. The user may find the following booklet prepared by the Federal Communications Commission helpful:

"How to Identify and Resolve Radio-TV Interference Problems".

This booklet is available from the U.S. Government Printing Office, Washington, DC 20402, Stock No. 004-000-00345-4.

### CANADA

THIS DIGITAL APPARATUS DOES NOT EXCEED THE "CLASS B" LIMITS FOR RADIO NOISE EMISSIONS FROM DIGITAL APPARATUS SET OUT IN THE RADIO INTERFERENCE REGULATIONS OF THE CANADIAN DEPARTMENT OF COMMUNICATIONS.

LE PRESENT APPAREIL NUMERIQUE N'EMET PAS DE BRUITS RADIOELECTRIQUES DEPASSANT LES LIMITES APPLICABLES AUX APPAREILS NUMERIQUES DE LA "CLASSE B" PRESCRITES DANS LE REGLEMENT SUR LE BROUILLAGE RADIOELECTRIQUE EDICTE PAR LE MINISTERE DES COMMUNICATIONS DU CANADA.

# NAMES AND FUNCTIONS OF CONTROLS AND TERMINALS

## FRONT PANEL

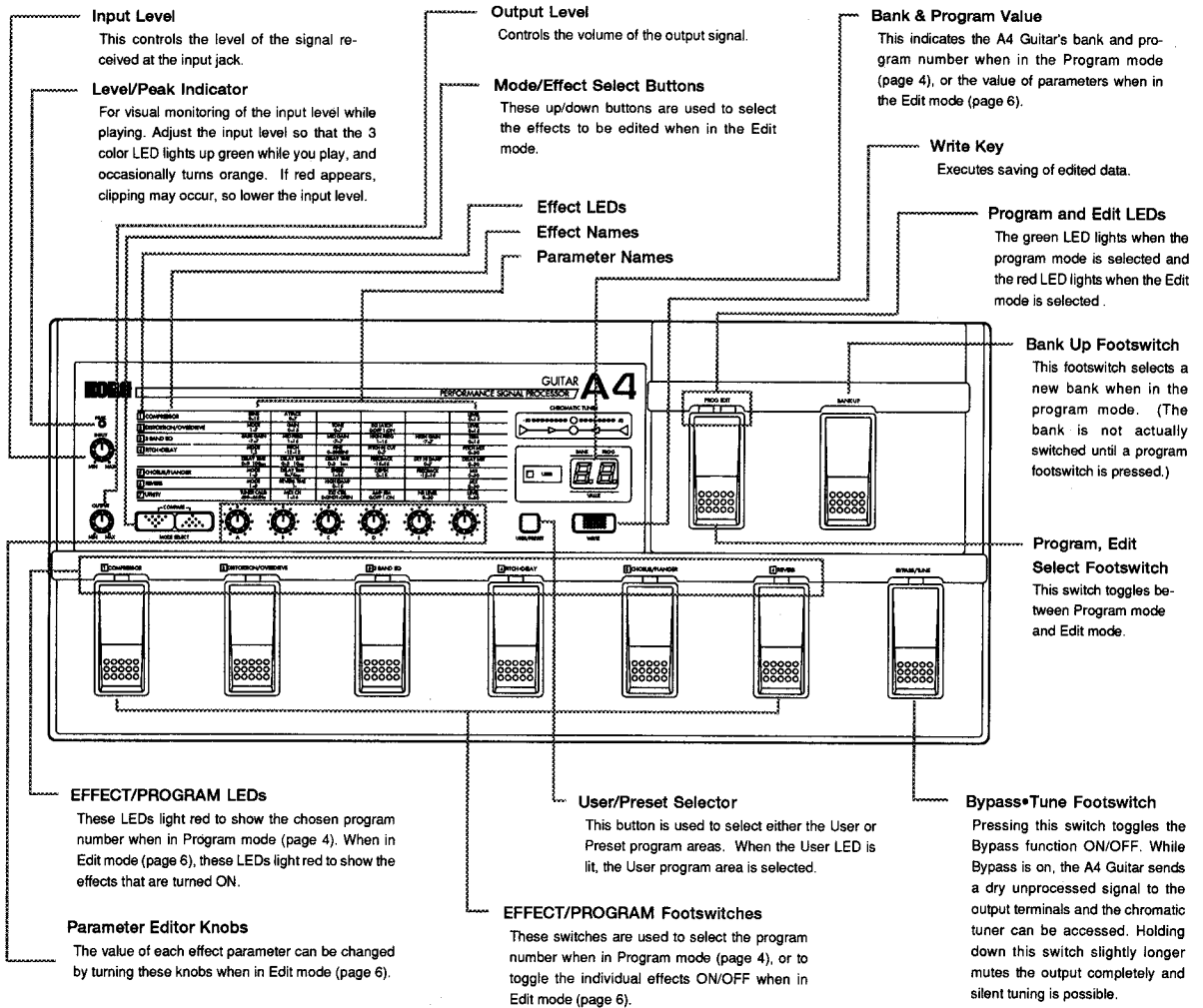

## REAR PANEL

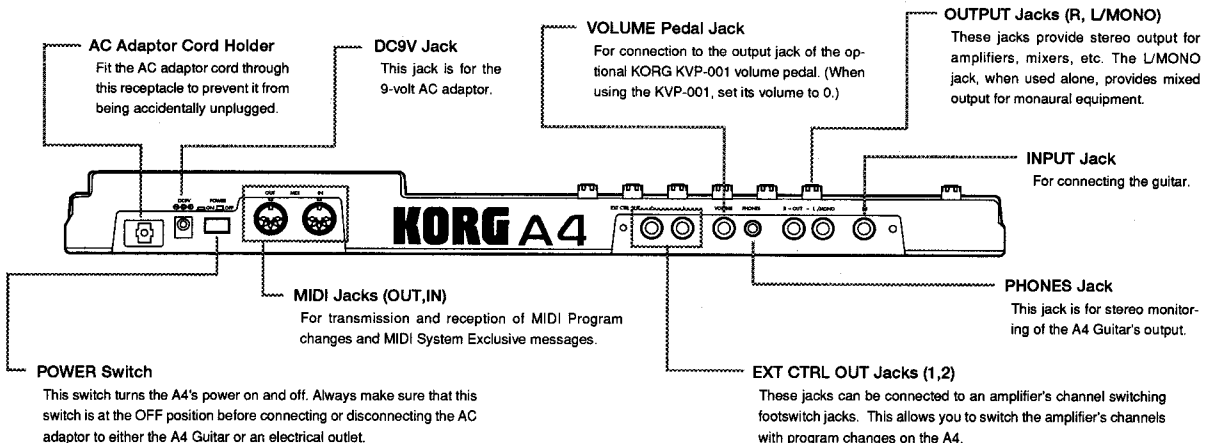

# CONNECTION WITH A GUITAR

1. Connect a guitar to the INPUT jack on the A4's rear panel.
2. Connect your guitar amplifier(s) to the OUTPUT jack(s) on the A4's rear panel. (For best results, use both jacks for stereo output to two amplifiers. For monaural (one amplifier) operation, connect to the L/MONO jack only.)
3. For volume pedal control, connect the optional KORG KVP-001 volume pedal. (See page 9 for more details.)
4. Input signals can be monitored in stereo by connecting a pair of stereo headphones to the PHONES jack.
5. After completing connection with instruments and equipment, turn on the A4 Guitar's power.
6. When playing the guitar, the peak indicator, which moves in accord with the input volume level, will go from green to yellow to orange to red. When increasing the input volume or playing the guitar strongly, please do not allow the indicator to go into the red area.
7. Please set the output volume appropriately. Following the above will allow for performance conditions.

NOTE: When turning the A4 Guitar on and off, make sure to turn all volume controls on all instruments and equipment down as far as they will go.

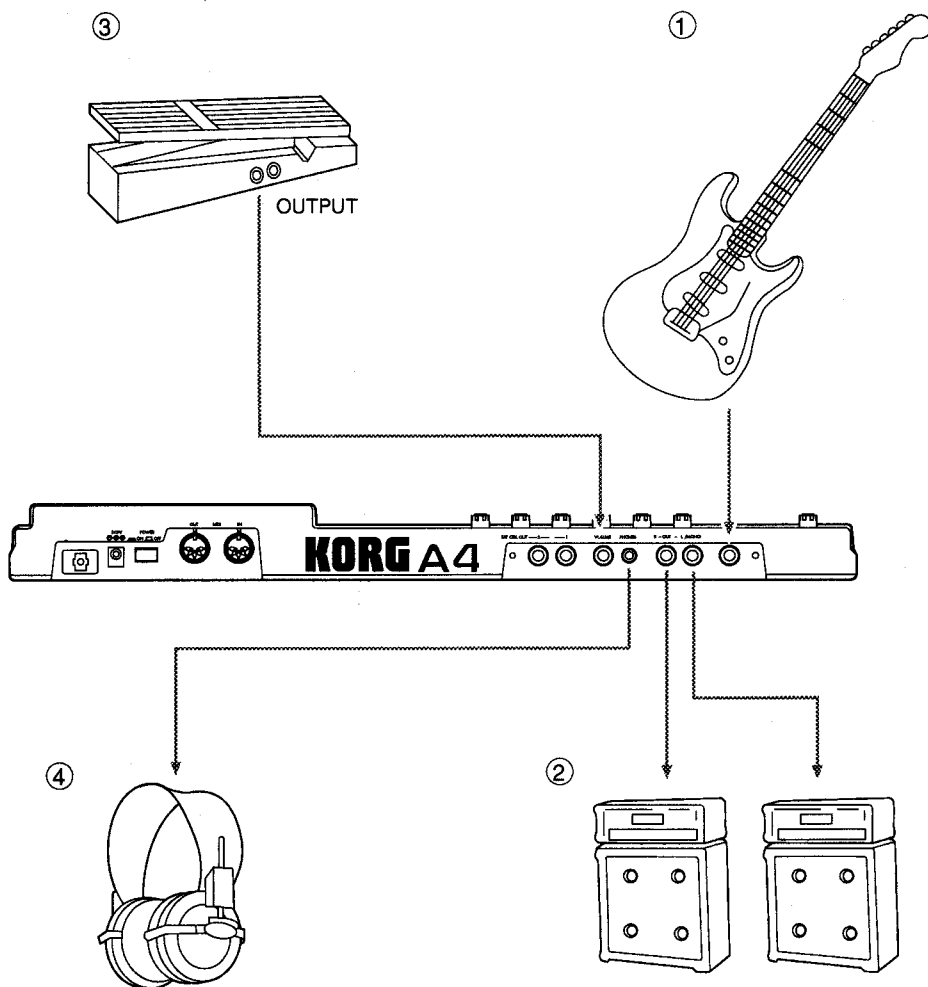

# PLAYING PRESET PROGRAMS

## [PROGRAM MODE]

### About Preset Programs

The A4 Guitar has a total of sixty (60) effects programs, including thirty (30) user programs and thirty (30) preset programs. It is possible to edit the preset programs, but these edited versions must be stored to the user program area. The user area is also used to store original, user-created programs. Each program area consists of five memory banks, each capable of holding six programs.

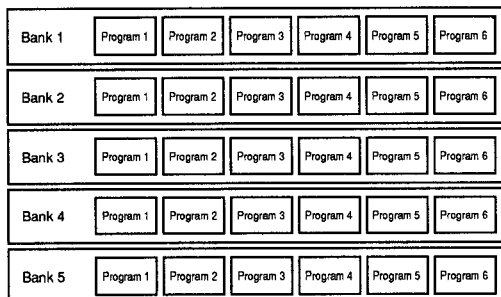

Preset Program area  
(Read Only Memory)

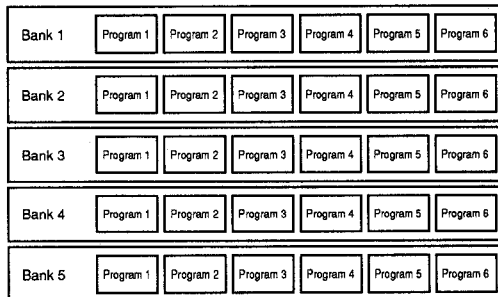

User Program area  
(Random Access Memory)

- When the power is first turned on, the A4 Guitar automatically enters Program mode. If you are in the Edit mode, simply press the Prog Edit Select switch to go to the Program mode.

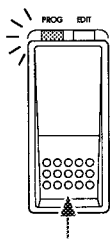

Press the switch until the green PROG LED lights up.

- Set the input level while playing the guitar. Adjust the input level so that the 3 color LED lights up green while you play and occasionally turns orange. If red appears, clipping may occur, so lower the input level.



Adjust the input level so that the Peak Indicator lights up as described above.

- Select the Preset Program mode. Preset Program mode is selected when the User LED is off. If the User LED is lit, press the User/Presets key to turn off the User LED.

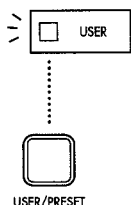

- Select a new bank by pressing the Bank Up footswitch.
- Press any of the EFCT/PROG switches (1 thru 6) to select the effect program you wish to play. For example, if Bank 1, Program 1 is selected, the LED should read as below.

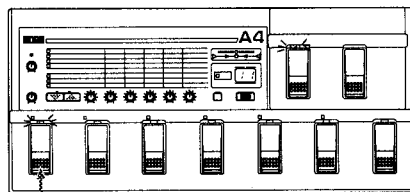

Program 1 in Bank 1 is selected.

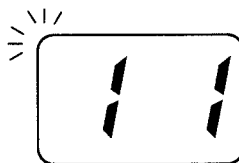

The bank and program numbers blink in the display when changed.

- Play the guitar to hear the effect sound of program 1. To hear the unprocessed sound, press the Bypass•Tune switch. Pressing the Bypass•Tune switch again returns the effect sound. (Refer to page 12 for more information on the Bypass•Tune switch.)
- Repeat steps 4 and 5 to select the various programs stored in the A4. To select another program in the same bank, simply press the appropriate EFCT/PROG switch.

**NOTE:** Shifting to a different bank does not select programs in that bank directly. To select programs in a new bank, you must press one of the six EFCT/PROG switches after entering the new bank.

# OPERATING INDIVIDUAL EFFECTS

## [EDIT MODE]

The A4 Guitar's effect system consists of six basic effects that are connected in a row, as in the diagram below. Each individual effect can be edited and combined with other effects to create an effect program. Each of the six effects in a program can be independently turned on and off.

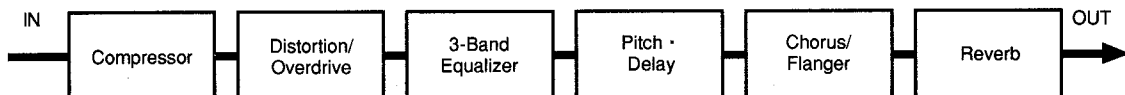

1. Press the Prog Edit Select switch to enter the Edit mode. The red LED lights up, and the Bank&Program/Value display changes to indicate that the machine is on Edit stand-by.

2. Press the EFCT/PROG switches to toggle the effects on and off. For example, pressing the EFCT/PROG switch immediately under (1) COMPRESSOR turns on that effect.

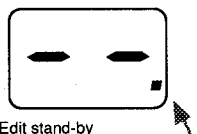
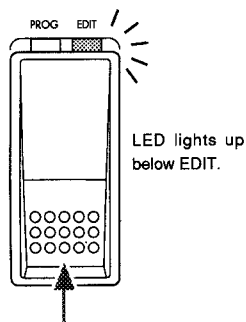

Refer to page 9 for more details on the dot.

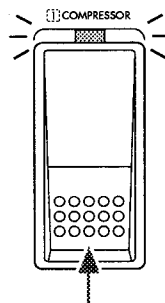

The function of the EFCT/PROG LEDs also changes. In the Edit mode, the EFCT/PROG switches control the ON/OFF status of each of the six different effects. The EFCT/PROG LEDs light to display the effects which are currently turned on.

For example, the following display appears when the Edit mode is selected after selecting Program 1 in Program mode. This is the first effect program in Bank 1.

3. Press the EFCT/PROG switches once again to turn off the effect. Try different effect combinations to hear variations in the processed sound.
4. To select and hear individual effects in another program, you must first return to Program mode. To do so, press the Prog Edit select switch. The Prog Edit LEDs, the EFCT/PROG LEDs, and the Bank&Program Value display return to their Program mode indication. Now, select a new program and press the Prog Edit Select switch again to return to the Edit mode.

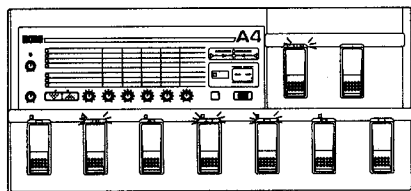

Program 1-1 consists of three effects: DIST/OD, PITCH-DELAY, and CHORUS/FLANGER.

The LED Indicates bank and program number when in Program mode.

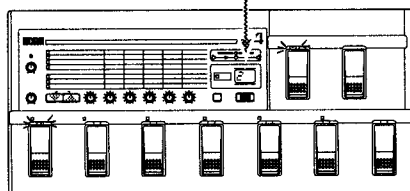

# CREATING ORIGINAL PROGRAMS

## [EDIT MODE]

### About Parameters and Editing

"Editing" involves altering the settings of individual effects, such as the balance between direct sound and effect output. "Parameters" are those specific settings within each effect, that can be edited.

#### Preset area

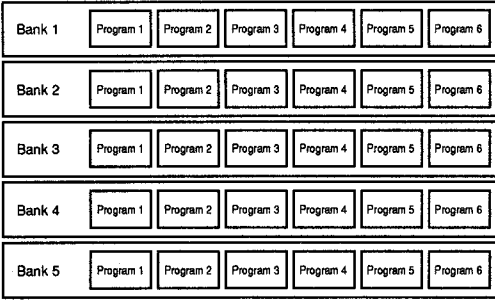

#### User Program area

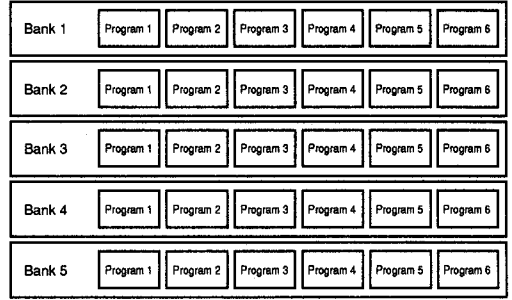

1. Enter Program mode and find a program that sounds closest to what you want. The example below shows selection of Program 1 in Bank 1.
2. Enter Edit mode by pressing the Prog Edit Select switch. The Prog Edit LEDs, the Value display, and the EFCT/PROG LEDs will change to indicate Edit mode.

The parameters for this program have been initially set as follows:

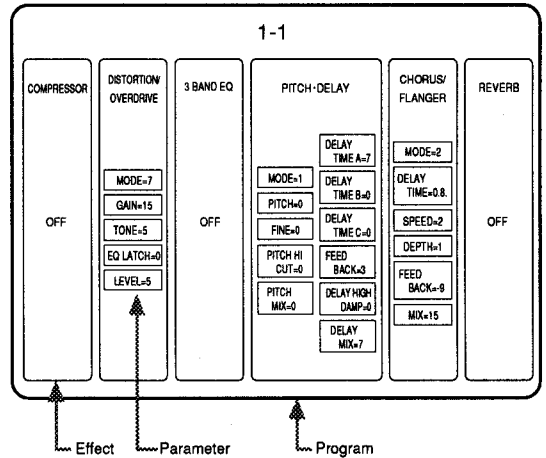
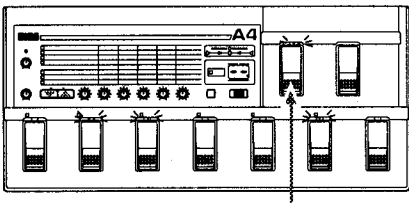



3. Press the Effect (Mode) Select buttons to choose the effect you wish to edit. The figure below shows selection of distortion/overdrive [DIST/OD], for example.

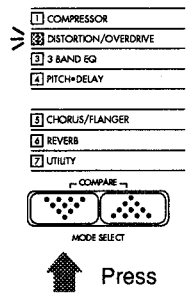

4. Find the parameter you wish to edit from the parameter names on the front panel. Adjust that parameter by turning the Parameter Editor knob (A thru F) directly below it. To change the GAIN parameter of DIST/OD, for example, turn the Parameter Editor knob B below GAIN. You should notice that the distortion varies as the GAIN value changes.

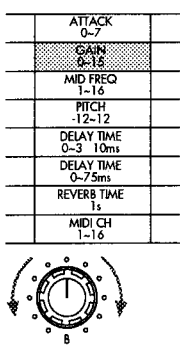

5. Turning the Parameter Editor changes the parameter values on the Value display. (A dot next to a parameter value number indicates the current programmed value.)



Refer to page 9 for an explanation of the dot to the right of the figure.

6. To edit other parameters, use the Mode (Effect) Select buttons and Parameter Editor knobs. (Each of the individual parameters is explained on pages 13 thru 17. See the Effect Parameter List for the parameter values of each preset program.)

NOTE: It is possible to edit the parameters of an effect which is turned off. Simply make sure that the Effect LED selector is in the position of the effect you wish to edit (use the Mode (Effect) buttons).

7. To edit other programs, switch back to Program mode and begin the procedure again. If you wish to save the edited program, perform the Program Write operation explained on page 8.

CAUTION: Selecting another program without performing the Program Write operation causes loss of the previously edited data.

## UTILITY

The Utility mode is provided to set parameters used for the A4 as a whole and also parameters necessary for each program as a whole (non-effect parameters).

### TUNER CALIB (Calibration)

This is used to set the tuner's standard pitch. (See page 12 for more details about the tuner.)

### MIDI CH (MIDI Channel)

This function is used to set the MIDI channel and for system exclusive transmission and reception of program data. (See page 10 for more details regarding MIDI Dump.)

### EXT CRTL (External Control)

Used to set the status of External Control jacks for each of the programs. (See page 11.)

### AMP SIM (Amplifier Simulation)

Activates or deactivates amplifier simulation for each program.

### NR LEVEL (Noise Reduction Level)

Used to set the noise reduction threshold level for each program.

### MASTER (Master Volume)

Allows setting of the output level for each of the programs. The procedure for adjusting these parameters is the same as the editing procedures in Edit mode.

# SAVING EFFECT PROGRAMS [PROGRAM WRITE]

It is possible to save up to 30 edited effect programs to the User area using the Program Write function. Unless you use this function to save the data, the changes you have made to the current program will be erased as soon as you select another program.

**NOTE:** Saving a program into a particular program number in the User area will erase program data currently residing at that number. (Before leaving the KORG factory, the data from the A4's Preset area is copied to the user area.)

## User Program area

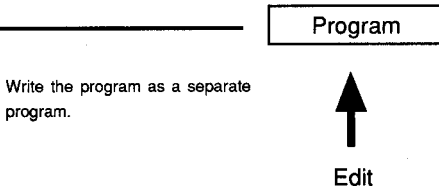
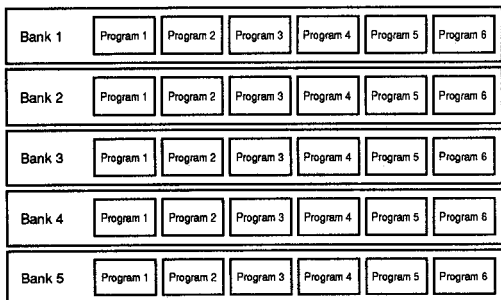

Write the program as a separate program.

- When editing is completed in Edit mode, press the Write key to save the currently edited program. For this example, an edited version of Bank 1-Program 1 is saved as a new program.

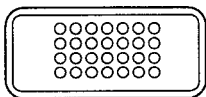

**WRITE**



- If, for example, the third program in Bank 4 is selected, the display should indicate as follows:

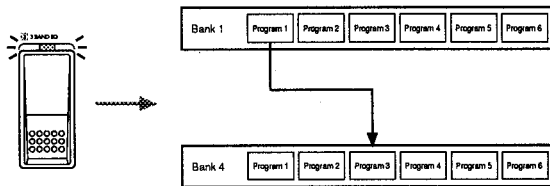

Select the program number to which the new program will be written.

- The User LED lights up and the current bank/program number blinks on the Value display. The flashing number indicates that the currently edited program is ready to be written to that particular program number.

Whether it is an edited version of a user program or a preset program, it will be stored in the User Program area.

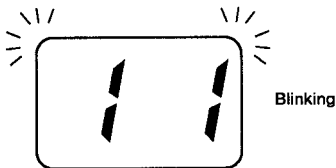

- Press the Write key again. Once writing is completed, both Mode-LEDs will stop blinking, and you will be returned to the Edit mode.

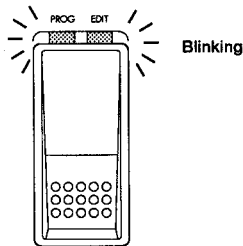

- Select the program number to which the new program will be written. Press the Bank Up key to select a particular bank and one of the six EFCT/PROG switches to select a particular program number.

\* To cancel the write operation, press the Prog Edit Select footswitch. The Write function can also be accessed directly from Program mode. This feature is useful when you wish to select programs you like and place them in a different order (in the User Programs).

# OTHER USEFUL FUNCTIONS

## 1. Comparison with Preset Program Parameters

The dot on the Value display assists you in editing by providing information in either the User Program or Preset Program area. The dot appears on the display for your reference in the following cases:

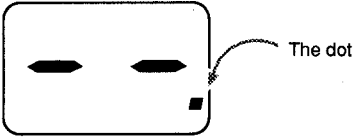

When the current effect On/Off status matches the program a dot appears.



When editing program parameters. A dot appears to the lower right of the value entered if it is the same as the value in the saved version of the program.

### • Compare Function

The A4 also has a compare function which allows you to switch back and forth between edited and saved versions a programs. To use the compare function, simply press the up and down Mode/Effect select buttons together. To return to the edited version of the program, press these buttons again.

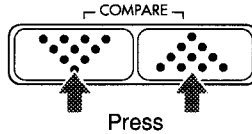

## 2. Using a Volume Pedal

With a volume pedal, it is possible to create a long, slow attack sound by gradually pressing down on the pedal after playing a chord or single note.

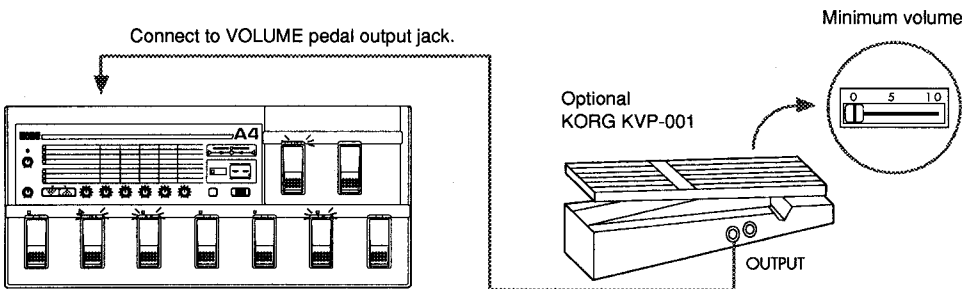

Connect the optional KORG KVP-001 volume pedal's output jack (OUTPUT) into the VOLUME pedal jack (PEDAL) of the A4 Guitar. Make sure that the KVP-001's volume slider has been set to the minimum volume of 0.

### 3. MIDI

The A4 Guitar features capabilities for transmitting and receiving MIDI program change messages as well as MIDI dump and load operations.

#### Saving All Program Parameters (MIDI Dump)

1. Connect the MIDI OUT of the A4 Guitar to the MIDI IN of a MIDI data filer.

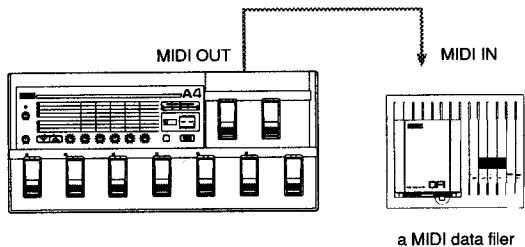

2. Set the external device to receive MIDI data.
3. In the Edit utility mode, select a MIDI channel for transmitting MIDI data.

ATTACK	0-7
GAIN	0-15
MID FREQ	1-16
PITCH	-12-12
DELAY TIME	0-3 10ms
DELAY TIME	0-7.5ms
REVERB TIME	1s
MIDI CH	1-16

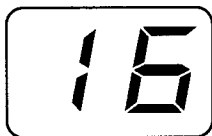

4. With the MIDI channel lit in the display, press the Write switch. The Value display changes to read "tr" (transmit) as the effect program parameters are transmitted.

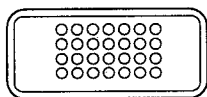

WRITE



Press

5. The MIDI channel indication reappears in the display again upon completion of transmission.

#### Loading All Program Parameters

1. Connect the MIDI IN of the A4 Guitar to the MIDI OUT of a MIDI data filer.

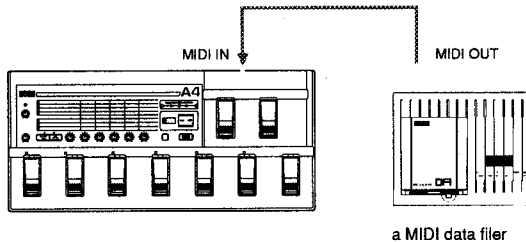

2. In the Edit utility mode, select a MIDI channel for receiving MIDI data.

ATTACK	0-7
GAIN	0-15
MID FREQ	1-16
PITCH	-12-12
DELAY TIME	0-3 10ms
DELAY TIME	0-7.5ms
REVERB TIME	1s
MIDI CH	1-16

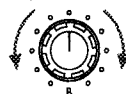

3. With the MIDI channel lit in the display, transmit the data to the A4 Guitar from the external device. The Value display changes to read "rc" (receive), as the effect program data is automatically loaded.
4. The MIDI channel indication reappears in the display again upon completion of the loading process.

NOTE: It is not possible to save or load program parameters if there is no MIDI channel visible in the display. Please select a MIDI channel (as described above) before saving or loading MIDI data. Also, the MIDI channel setting must be the same as when the data was originally sent.

## 4. External Control

The A4 Guitar is equipped with two external control outputs. This function allows you to simultaneously switch the channels of one or two amplifiers with a program change on the A4 Guitar. The open/close status of each EXT CTRL OUT jack can be set by using the External Control utility in Edit mode. This function is useful if you would like to switch between your amplifier's clean and distorted channels, thereby incorporating the amplifier's built-in distortion/overdrive with the A4's other effects.

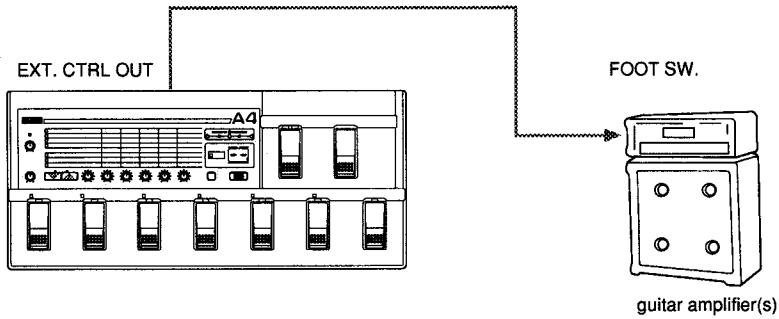

### SYSTEM RESET

To reset the A4 to factory settings:

Hold down the WRITE key and BANK UP footswitch while turning the A4 on. The display will flash "PL". Press WRITE again to load the factory presets into the USER program area.

Note: This procedure will erase all programs stored in the USER program area. Please save any important programs to a MIDI data file or copy the parameter values on a piece of paper.

# TUNER

A digital auto tuner is built into the A4 Guitar.

## 1. Bypass • Tune switch

If this switch is pressed, the Bypass LED lights and all effects are turned off.

At the same time, the tuner is turned on.

If the switch is held for approximately one second after reaching the Bypass condition, the Mute function is activated, and silent tuning is possible.

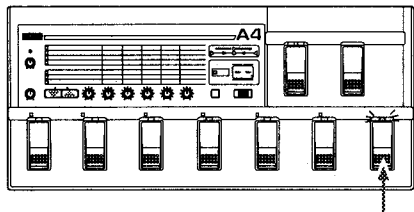

## 2. Standard Pitch and Calibration

For tuning with other musical instruments, "middle A" or "A440" (A=440Hz) has traditionally been used as the standard pitch. It is known that this standard pitch has varied slightly from time to time and country to country. With this tuner, you can set the standard pitch for the A4 Guitar in the 438-445Hz range.

Calibration refers to the setting of the standard pitch.

Calibration is performed by using the Calibration utility in Edit mode.

## 3. Example of tuning

	6	5	4	3	2	1
standard tuning	E	A	D	G	B	E
flat tuning	D#	G#	C#	F#	A	D#
open-D-tuning	D	A	D	F#	A	D
open-G-tuning	(D)	G	D	G	B	D

## 4. Tuning

- When a note is played on the guitar, the name of the note best representing the sound is indicated in the display. (Do not play two or more notes at the same time.)



- If a wrong note is indicated, the tension of the guitar's string should be adjusted such that the note on the display shows the correct note for the string.
- Once the string's tension is properly adjusted and the correct note is indicated in the display, adjust the string's tension so that only the green center LED in the LED panel lights up.

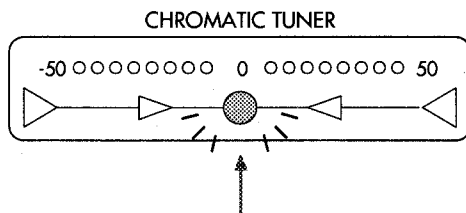

- Tune the other strings by repeating steps 1 through 3.
- If the Bypass•Tune switch is pressed again, the tuner becomes inactive, canceling the Bypass function.

# EFFECT PARAMETER LIST

## 1. COMPRESSOR [COMPRESSOR]

◆ The COMPRESSOR enables the system to maintain a constant output level by compressing input signals. This effect helps emphasize the attack sound while picking or helps lengthen the sustain sound by raising the level as the sound decays.

### ◆ Parameters

<b>A</b>	SENS (SENSITIVITY)	[0 ~ 15]	The threshold of the compressor effect. This specifies at what signal level the compressor will start working.
<b>B</b>	ATTACK	[0 ~ 7]	Attack time. "0" setting is slow attack, and "7" is fast.
<b>F</b>	LEVEL	[0 ~ 15]	Effect sound level output.

### ★ Note

Set the input volume correctly.

The degree of the compressor's effect varies greatly according to the input signal. In other words, the effect may be enhanced or reduced by the setting of input volume. The input volume should therefore be set properly in accordance to the peak indicator. (See page 4.)

## 2. DISTORTION/OVERDRIVE [DIST/OD]

◆ DISTORTION/OVERDRIVE function adds distortion to the input sound (simulating the characteristics of an overdriver amplifier).

### ◆ Parameters

<b>A</b>	MODE	[1 ~ 7]	<p>1: Tube OD This mode features natural distortion unique to tube amplifiers.</p> <p>2: Classic OD Similar to Tube OD, but with more direct attack sound.</p> <p>3: Super OD This overdrive has a peak in the middle frequency band.</p> <p>4: Dist This mode produces a smooth distortion with high gain.</p> <p>5: Super Dist This is distortion with a peak in the middle frequency band.</p> <p>6: Stuck Wah Dist This mode produces a distortion sound and simulates the effect of a wah pedal pressed halfway down.</p> <p>7: Metal Dist. This mode produces a harder edged distortion suitable for heavy metal.</p>
<b>B</b>	GAIN	[0 ~ 15]	Distortion amount (drive).
<b>C</b>	TONE	[0 ~ 7]	This is used to set the tone. The larger this value, the brighter the sound.
<b>D</b>	EQ LATCH	[0, 1]	<p>This allows the 3 BAND EQ effect to be switched on/off automatically when the DISTORTION/OVERDRIVE effect is switched on/off.</p> <p>0: EQ is not latched to DISTORTION/OVERDRIVE.</p> <p>1: The equalizer will be turned on/off whenever DISTORTION/OVERDRIVE is turned on/off.</p>
<b>F</b>	LEVEL	[0 ~ 15]	Effect sound output level.

### 3. 3 BAND EQ

◆ An equalizer with three frequency bands: BASS, MIDDLE, and TREBLE. The center frequencies for the middle and high bands are programmable.

◆ Parameters

<b>A</b>	BASS (BASS GAIN)	[- 7 ~ 7]	Gain (amplification degree) for the low band.
<b>B</b>	MID FREQ (MIDDLE FREQUENCY)	[1 ~ 16]	The center frequency for the middle band equalizer. The larger this value, the higher the center frequency. 1:250 2:350 3:450 4:550 5:650 6:700 7:750 8:800 9:850 10:900 11:950 12:1.00k 13:1.25k 14:1.5k 15:2.0k 16:2.5k
<b>C</b>	MID GAIN (MIDDLE GAIN)	[- 7 ~ 7]	Gain for the middle band equalizer.
<b>D</b>	HIGH FREQ (HIGH FREQUENCY)	[1 ~ 16]	The center frequency for the high band equalizer. The larger this value, the higher the center frequency. 1:850 2:900 3:950 4:1.00k 5:1.25k 6:1.5k 7:2.0k 8:2.5k 9:3.0k 10:3.5k 11:4.0k 12:4.5k 13:5.0k 14:5.5k 15:6.0k 16:6.5k
<b>E</b>	HIGH GAIN	[- 7 ~ 7]	Gain for the high band equalizer.
<b>F</b>	TRIM	[0 ~ 15]	Gain for the input signal.

★ Note

Use TRIM to prevent clipping.

If the gain for each frequency band is raised near its maximum, the output may be distorted (or clipped) even when the PEAK LED is not lit. In such situations, turn down the TRIM parameter until the clipping stops.

### 4. PITCH•DELAY

◆ PITCH•DELAY is an effect generated by combining a PITCH SHIFTER which changes the pitch of the input sound, and a DELAY, which creates repeats of the input sound.

◆ There are two different modes: the PITCH + DELAY Mode in which the PITCH SHIFTER and the DELAY are independent, and the SWEEP DELAY Mode, in which the pitch becomes increasingly higher or lower as the DELAY effect repeats.

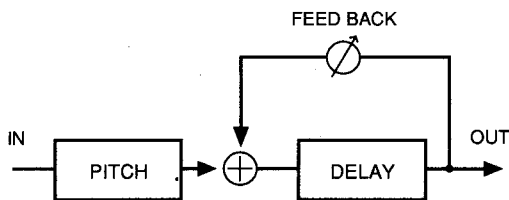

MODE 1 —PITCH + DELAY—

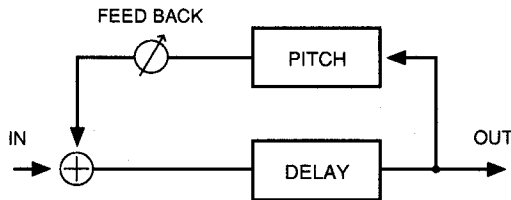

MODE 2 —SWEEP DELAY—

★ Note

If you wish to have only the PITCH SHIFTER effect:

Select MODE 1 and set DELAY MIX at "0."

If you wish to have only the DELAY effect:

Select MODE 1 and set PITCH MIX at "0."



PITCH SHIFT Block			
<b>A</b>	MODE	[1, 2]	The function is used to select one of the following modes, PITCH SHIFTER and the DELAY. 1: the PITCH SHIFTER and the DELAY are independent. 2: the PITCH SHIFTER is incorporated in the DELAY feedback loop.
<b>B</b>	PITCH	[-12 ~ 12]	The PITCH function is used to set the PITCH SHIFTER's pitch in half-tone steps within the variable range. (12 half tones = 1 octave)
<b>C</b>	FINE (PITCH FINE)	[0 ~ 98]	The FINE function is used to set the PITCH SHIFTER's pitch in 1 cent steps within the variable range. (100 cents = 1 half tone) The sum of the values set by PITCH and FINE represents the actual variable tone range.
<b>D</b>	PITCH HIGH CUT	[0 ~ 7]	The PITCH HIGH CUT function is used to set the high cut filter which is to be applied to pitch-shifted sound. The larger this value, the darker the pitch-shifted sound.
<b>F</b>	PITCH MIX	[0 ~ 30]	The PITCH MIX function is used to set a mix ratio between the direct sound and the Effect sound (pitch-shifted sound) in the PITCH SHIFTER block in MODE 1. The setting "0" produces only the direct sound, while "30" produces only the effect sound. This parameter does not operate in MODE 2.

DELAY Block			
<b>A</b>	DELAY TIME	[0 ~ 9]	The DELAY TIME A function is used to set the delay time in increments of 100m sec.
<b>B</b>	DELAY TIME	[0 ~ 9]	The DELAY TIME B function is used to set the delay time in increments of 10m sec.
<b>C</b>	DELAY TIME	[0 ~ 9]	The DELAY TIME C function is used to set the delay time in increments of 1m sec. The sum of the values set by DELAY TIMES A, B and C functions represents the actual delay time.
<b>D</b>	FEEDBACK	[-15 ~ 15]	The FEEDBACK function is used to set the amount of delay feedback (number of repeats). The larger this value, the higher the number of repeats. Negative values produce repeats with inverted phase.
<b>E</b>	HIGH DAMP	[0 ~ 7]	The HIGH DAMP function is used to set the amount of high damp. The larger this value, the more the high band portion of the delay sound is cut every time the signal is repeated.
<b>F</b>	DELAY MIX	[0 ~ 30]	The DELAY MIX function is used to set the mix ratio between the delay sound and the direct sound. The setting "0" produces only the direct sound, while "30" produces only the effect sound.

## 5. CHORUS/FLANGER

- ◆ This effect creates a swirling, warm sound by cyclically modulating the sound's pitch. Depending on how the parameters are set, you can obtain both CHORUS and FLANGER.

### ★ Creating CHORUS and FLANGER effects

#### CHORUS

- 1) Select MODE 1.
- 2) Set the DELAY TIME to 10m sec. or more.
- 3) Set the FEEDBACK to "0."

#### FLANGER

- 1) Select MODE 2.
- 2) Set the DELAY TIME to 5msec. or less. In the case of the FLANGER, the shorter the DELAY TIME, the higher the pitch of the modulation.
- 3) Set the FEEDBACK to 7 or more (or -7 or less [negative values = inverted phase]). The higher the FEEDBACK setting, the stronger the modulation.

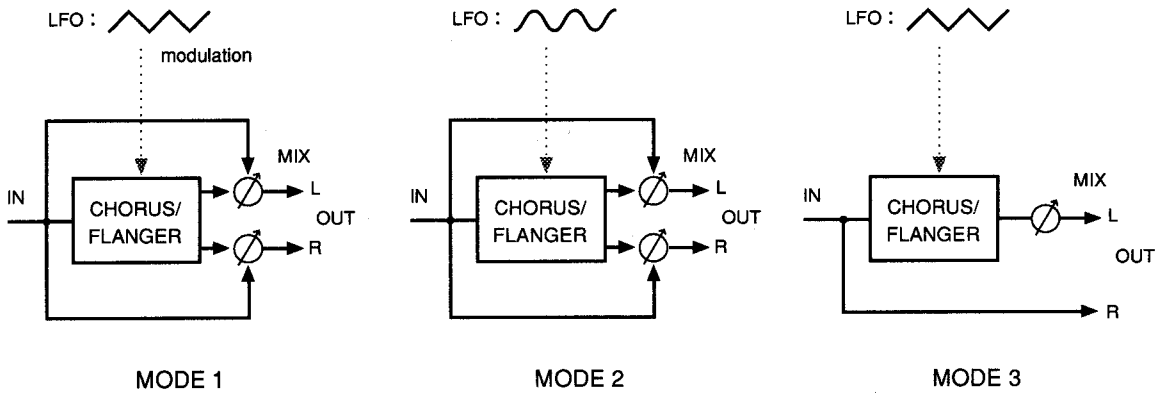

### ◆ Parameters

<b>A</b>	MODE	[1 ~ 3]	1: Stereo CHORUS/FLANGER with LFO=TRI (triangle wave). 2: Stereo CHORUS/FLANGER with LFO=SIN (sine wave). 3: With LFO=TRI, this mode sends the wet signal through the left channel and the dry (direct) sound through the right channel.
<b>B</b>	DELAY TIME	[0.0 ~ 75msec]	The DELAY TIME function is used to set the time between the dry signal and the wet signal. When used together with the feedback parameter, it controls the frequency of the resonance
<b>C</b>	SPEED	[1 ~ 16]	The SPEED function is used to set the speed of modulation.
<b>D</b>	DEPTH	[0 ~ 15]	The DEPTH is used to set the depth of modulation. The larger this value, the greater the modulation.
<b>E</b>	FEEDBACK	[-15 ~ 15]	The FEEDBACK function is used to set the amount of feedback. Negative values = inverted phase.
<b>F</b>	MIX	[0 ~ 30]	The MIX function is used to set the mix ratio between the effect sound and the direct sound. The setting "0" produces only the direct sound, while "30" produces only the effect sound.

## 6. REVERB (Reverberation)

- ◆ The REVERB effect gives spatial depth to a sound by simulating the reverberation characteristics of natural listening environments, such as a concert hall or a room.
- ◆ Parameters

<b>A</b>	MODE	[1 ~ 3]	1: Room Reverberation 2: Hall Reverberation 3: Plate Reverberation
<b>B</b>	REVERB TIME	[0.3 ~ 2.0] sec. (Room:) [0.4 ~ 10] sec. (Hall&Plate:)	The REVERB TIME function is used to set the reverberation time.
<b>C</b>	HIGH DAMP	[0 ~ 15]	The HIGH DAMP function is used to set the amount of high-frequency damping. The larger this value, the darker the tone as the reverberation decays.
<b>F</b>	MIX	[0 ~ 30]	The MIX function is used to set the mix ratio between the effect sound and the direct sound. The setting "0" produces only the direct sound, while "30" produces only the effect sound.

## 7. UTILITY

- ◆ The UTILITY function allows for the setting of various parameters other than effect parameters.
- ◆ Parameters

<b>A</b>	TUNER CALIB (Tuner Calibration)	[438 ~ 445]	The TUNER CALIB function is used for calibrating the tuner by setting the pitch for "middle A" within the frequency band of 438Hz to 445Hz. Values on the display vary between 38 and 45, representing a possible frequency between 438 and 445Hz. It is normally set at 440Hz. The value set here will be stored in memory without the need for any PROGRAM WRITE procedures.
<b>B</b>	MIDI CH (MIDI Channel)	[1 ~ 16]	The MIDI CH function is used to set a MIDI transmission/reception channel. Values set here will be stored in memory without the need for any PROGRAM WRITE procedures.
<b>C</b>	EXT. CTRL (External Control)	[00, 10, 01, 11]	The EXT. CTRL function enables you to switch your amplifier's channels from A4 program changes. Two EXT CNTRL Jacks are provided for use with two amplifiers. The left value represents the setting of EXT. CTRL. OUT 1 (0=CLOSED; 1=OPEN) The right value represents the setting of EXT. CTRL. OUT 2 (0=CLOSED; 1=OPEN)
<b>D</b>	AMP SIM (Amplifier Simulation)	[0, 1]	The AMP SIM function is used to activate or deactivate the amplifier simulation function which reproduces a guitar amplifier's frequency characteristics when the A4 Guitar's output is directly connected to a mixer, etc (line out). 0: Amplifier Simulation is off (use when connected to a guitar amplifier) 1: Amplifier Simulation is on (line out)
<b>E</b>	NR LEVEL (Noise Reduction Level)	[0 ~ 30]	The NR LEVEL parameter is used to set the threshold level of the built-in noise reduction function. In setting this level, with the guitar connected to the A4, start with the lowest NR LEVEL value and raise this value, with the strings muted, until almost no noise is perceivable.
<b>F</b>	LEVEL	[0 ~ 30]	The LEVEL function is used to set the overall output level of each effect program.

### ★ Note

Among these UTILITY parameters, the values for TUNER CALIB and MIDI CH are the same in all effect programs. It is therefore impossible to set different parameters for each effect program separately.

## ERROR MESSAGES



### BL (Battery Low)

When the above message appears immediately after turning on the A4 Guitar the battery for internal memory backup needs to be replaced. Contact the KORG distributor nearest you or your local KORG dealer or service center, and have a qualified technician replace it.

## TROUBLESHOOTING

If a problem occurs during normal operation of the A4 Guitar, follow the suggestions below and check the A4 Guitar to spot and remedy the trouble. If the A4 Guitar still does not function properly, consult the KORG distributor nearest you or your local KORG dealer.

Trouble	Countermeasure
No sound.	<ol style="list-style-type: none"> <li>1. Check if the Input volume or the Output volume is set to 0. Adjust the level until the input signal reaches a level strong enough to light the Peak LED (green or orange), or raise the output volume until sound can be monitored with headphones.</li> <li>2. It is possible that the level parameter in one of the effects may be set to 0. In such a case, sound can be heard only when pressing the Bypass key. Adjust the appropriate level parameters.</li> <li>3. Check to see if the Utility mode's Master Volume is set to 0. If so, reset it to a suitable level.</li> <li>4. If a volume pedal is connected, it may be in the up or "no sound" position.</li> <li>5. The Bypass•Tune's mute function may be activated. Press the Bypass•Tune switch to deactivate.</li> </ol>
No effect. No change in effect when editing.	<ol style="list-style-type: none"> <li>1. Check the Prog Edit LEDs to ensure that Edit mode is selected.</li> <li>2. Check to ensure that the desired effect is properly selected using the EFFECT/PROGRAM Footswitches.</li> <li>3. Check to see if Bypass has been turned on. When the bank&amp;program/value display is blank, the A4 Guitar is in Bypass condition. Press the Bypass key to turn it off.</li> <li>4. Check to see if the Mix Level parameter in one of the effects is set to 0. If so, reset it to a suitable level.</li> <li>5. Check to see if any effects have been set to OFF. Make sure the EFCT/PROG LEDs are lit for the effects you wish to edit.</li> </ol>

# A4 MIDI Program Chart

MIDI Program	A4 Bank/Prog	MIDI Program	A4 Bank/Prog
Number	USER AREA	Number	PRESET AREA
1	11	31	11
2	12	32	12
3	13	33	13
4	14	34	14
5	15	35	15
6	16	36	16
7	21	37	21
8	22	38	22
9	23	39	23
10	24	40	24
11	25	41	25
12	26	42	26
13	31	43	31
14	32	44	32
15	33	45	33
16	34	46	34
17	35	47	35
18	36	48	36
19	41	49	41
20	42	50	42
21	43	51	43
22	44	52	44
23	45	53	45
24	46	54	46
25	51	55	51
26	52	56	52
27	53	57	53
28	54	58	54
29	55	59	55
30	56	60	56

A4 MIDI IMPLEMENTATION

1. TRANSMITTED DATA

1-1 Channel Messages

Status	Second	Third	Description
1100 nnnn	00pp pppp	---- ----	Program Change

nnnn : MIDI Channel Number  
 pp pppp : Program Number (0 - 59) (NOTE 1)

1-2 System Exclusive Messages  
 A4 System Exclusive

1st Byte = 1111 0000 (F0) : Exclusive Status	Ex.Header
2nd Byte = 0100 0010 (42) : KORG ID	
3rd Byte = 0011 nnnn (3n) : Format ID n:MIDI Channel	
4th Byte = 0011 0001 (31) : A4 ID	
5th Byte = 0fff ffff (ff) : Function Code	
6th Byte = 0ddd dddd (dd) : Data	
:	:
LastByte = 1111 0111 (F7) : End of Exclusive	

Func	Description	R	D	E
40	PROGRAM PARAMETER DUMP	o		
50	ALL PROGRAM DUMP	o	o	
26	RECEIVE MESSAGE FORMAT ERROR	o		o
23	DATA LOAD COMPLETED			o
24	DATA LOAD ERROR			o

Transmitted when

R : Request message is received  
 D : Data dump by switch  
 E : Exclusive message received

2. RECOGNIZED RECEIVE DATA

2-1 Channel Messages

Status	Second	Third	Description
1100 nnnn	00pp pppp	---- ----	Program Change

nnnn : MIDI Channel Number  
 pp pppp : Program Number (NOTE 1)  
 (Data beyond value of 59 are ignored.)

2-2 System Exclusive Messages

Func	Description
0F	ALL DATA DUMP REQUEST
10	PROGRAM PARAMETER DUMP REQUEST
40	PROGRAM PARAMETER DUMP
50	ALL DATA DUMP

3. MIDI EXCLUSIVE FORMAT (R : Receive, T : Transmit)

(1) ALL PROGRAM DUMP REQUEST

R

Byte	Description
FO, 42, 3n, 31	Exclusive Header
0000 1111	All Data Dump Request
0000 000m	Member Code
1111 0111	EOX

OF  
(NOTE 2)

Receives this message, and transmits Func=50 or Func=24 message.

(2) PROGRAM DUMP REQUEST

R

Byte	Description
FO, 42, 3n, 31	Exclusive Header
0001 0000	Data Dump Request
0000 000m	Member Code
1111 0111	EOX

10  
(NOTE 2)

Receives this message, and transmits Func=40 or Func=24 message.

(3) PROGRAM PARAMETER DUMP

R, T

Byte	Description
FO, 42, 3n, 31	Exclusive Header
0100 0000	Program Parameter Dump
0000 000m	Member Code
0ddd dddd	Data
...	...
1111 0111	EOX

40  
(NOTE 2)  
(NOTE 3)

Receives this message and data, and transmits Func=23 or Func=24 message.

Receives Func=10 message, and transmits this message and data.

(4) ALL PROGRAM DUMP

R, T

Byte	Description
FO, 42, 3n, 31	Exclusive Header
0101 0000	All Data Dump
0000 000m	Member Code
0ddd dddd	Data
...	...
1111 0111	EOX

50  
(NOTE 2)  
(NOTE 4)

Receives this message and data, and transmits Func=23 or Func=24 message.

Receives Func=0F message, and transmits this message and data.

Transmits this message and data by DUMP sw.

(5) MIDI IN DATA FORMAT ERROR

T

Byte	Description
FO, 42, 3n, 31	Exclusive Header
0010 0110	MIDI In Data Format Error
1111 0111	EOX

26

Transmits this message when there is an error in MIDI in message.

(6) DATA LOAD COMPLETED

T

Byte	Description
FO, 42, 3n, 31 0010 0011 1111 0111	Exclusive Header Data Load Completed EOX <span style="float: right;">23</span>

Transmits this message when DATA LOAD, PROCESSING have been completed.

(7) DATA LOAD ERROR

T

Byte	Description
FO, 42, 3n, 31 0010 0100 1111 0111	Exclusive Header Data Load Error EOX <span style="float: right;">24</span>

Transmits this message when DATA LOAD, PROCESSING have not been completed.

NOTE 1 : 00 - 29 : User Program  
30 - 59 : Preset Program

NOTE 2 : m = 0 : A4 GUITAR  
1 : A4 BASS

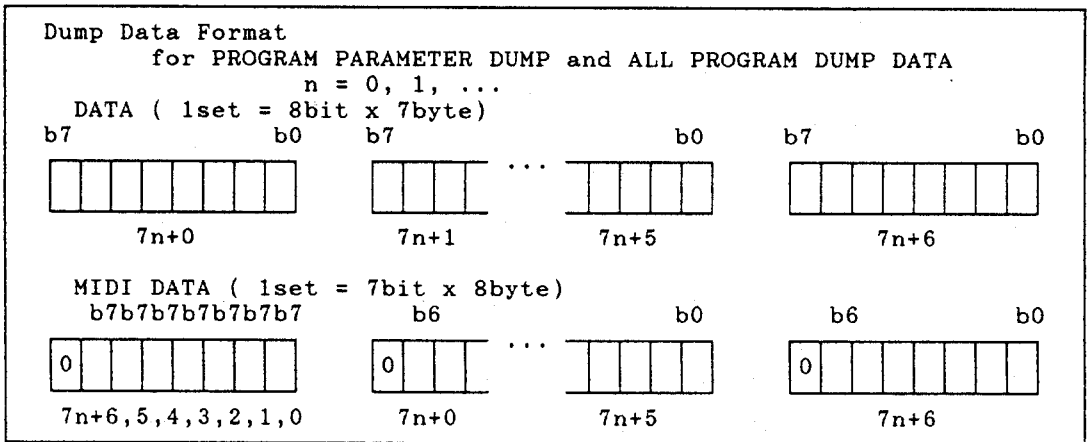

NOTE 3 : Program Parameter Dump Format  
21 = 7 x 3 --> 8 x 3 = 24byte

NOTE 4 : All Data Dump format  
[Prog.11 (21byte)], ... , [Prog.56 (21byte)]  
21 x 30 = 630 = 7 x 90 --> 8 x 90 = 720byte



GUITAR  
TABLE 1 PROGRAM PARAMETERS

OFFSET NO.	PARAMETERS	DATA(HEX) : VALUE
00	COMPRESSOR ON/OFF DISTORTION ON/OFF 3 BAND EQ ON/OFF PITCH / DELAY ON/OFF CHORUS / FLANGER ON/OFF REVERB ON/OFF EXTERNAL CONTROL 1 EXTERNAL CONTROL 2	bit 0 0:OFF, 1:ON bit 1 0:OFF, 1:ON bit 2 0:OFF, 1:ON bit 3 0:OFF, 1:ON bit 4 0:OFF, 1:ON bit 5 0:OFF, 1:ON bit 6 0:CLOSE, 1:OPEN bit 7 0:CLOSE, 1:OPEN
01	COMPRESSOR SENS COMPRESSOR LEVEL	bit 0~3 : 0 ~ 15 bit 4~7 : 0 ~ 15
02	DISTORTION GAIN DISTORTION LEVEL	bit 0~3 : 0 ~ 15 bit 4~7 : 0 ~ 15
03	3 BAND EQ BASS GAIN 3 BAND EQ MID FREQ	bit 0~3 0~14 : -7 ~ 7 bit 4~7 0~15 : 1 ~ 16
04	3 BAND EQ MID GAIN 3 BAND EQ HIGH FREQ	bit 0~3 0~14 : -7 ~ 7 bit 4~7 0~15 : 1 ~ 16
05	3 BAND EQ HIGH GAIN 3 BAND EQ TRIM	bit 0~3 0~14 : -7 ~ 7 bit 4~7 0~15 : 1 ~ 16
06	PTCH/DLY DELAY TIME x 100 PTCH/DLY DELAY TIME x 10	bit 0~3 : 0 ~ 9 bit 4~7 : 0 ~ 9
07	PTCH/DLY DELAY TIME x 1 CHO/FLA SPEED	bit 0~3 : 0 ~ 9 bit 4~7 0~15 : 1 ~ 16
08	CHO/FLA DEPTH REVERB TIME	bit 0~3 : 0 ~ 15 bit 4~7 0~15 : 1 ~ 16 *1
09	REVERB HIGH DAMP CHO/FLA MODE REVERB MODE	bit 0~3 : 0 ~ 15 bit 4~5 0~2 : 1 ~ 3 bit 6~7 0~2 : 1 ~ 3
10	PTCH/DELAY PITCH COMPRESSOR ATTACK	bit 0~4 0~24 : -12 ~ 12 bit 5~7 : 0 ~ 7
11	PTCH/DLY PITCH MIX DISTORTION MODE	bit 0~4 : 0 ~ 30 bit 5~7 0~6 : 1 ~ 7
12	PTCH/DLY FEEDBAK DISTORTION TONE	bit 0~4 0~30 : -15 ~ 15 bit 5~7 : 0 ~ 7
13	PTCH/DLY DELAY MIX PTCH/DLY DELAY HIGH DAMP	bit 0~4 : 0 ~ 30 bit 5~7 : 0 ~ 30
14	CHO/FLA FEEDBACK DISTORTION EQ LATCH PTCH/DLY MODE AMP SIMULATION	bit 0~4 0~30 : -15 ~ 15 bit 5 0:OFF, 1:ON bit 6 : 0, 1 bit 7 0:OFF, 1:ON
15	CHO/FLA MIX PTCH/DLY PITCH HIGH CUT	bit 0~4 : 0 ~ 30 bit 5~7 : 0 ~ 7
16	REVERB MIX	bit 0~4 : 0 ~ 30
17	PTCH/DLY PITCH FINE	bit 0~5 0~49 : 0 ~ 98
18	CHO/FLA TIME	bit 0~5 0~63 : 0 ~ 75
19	NOISE REDUCTION LEVEL	bit 0~5 : 0 ~ 30
20	MASTER VOLUME	bit 0~5 : 0 ~ 30

\*1 0.3 ~ 2.0 (mode 1)  
0.4 ~ 10 (mode 2,3)

## A4 MIDI Implementation Chart

Function	Transmitted	Recognized	Remarks
Basic Channel. Default Changed	1~16 1~16	1~16 1~16	Memorized
Mode Default Messages Altered	X .....	3 X	
Note Number : True Voice	X X	X X	
Velocity Note ON Note OFF	X X	X X	
After Touch Key's Channels	X X	X X	
Pitch Bender	X	X	
1~127	X	X	
Control Change			

Program Change	: True #	00~59 .....	00~59	*1
System Exclusive		○	○	*2
System Common	: Song Pos : Song Sel : Tune	X X X	X X X	
System Real Time	: Clock : Command	X X	X X	
Aux Message	: Local On/OFF : All Notes OFF : Active Sense : Reset	X X X X	X X X X	
Notes	*1. See MIDI Program Chart. *2. Transmittable and receivable only when the Utility is set to the MIDI channel.			

○ : Yes  
X : No

Mode 2 : OMNI ON, MONO  
Mode 4 : OMNI OFF, MONO

Mode1 : OMNI ON, POLY  
Mode3 : OMNI OFF, POLY

- For those who create their own programs, please do so within the guidelines set for the parameters. Please duplicate this page as necessary.

BANK NO	PROG NO	A4G PROG					
COMPRESSOR		SENS	ATTACK				LEVEL
DIST/OD		MODE	GAIN	TONE	EQ LATCH		LEVEL
3 BAND EQ		BASS GAIN	MID FREQ	MID GAIN	HIGH FREQ	HIGH GAIN	TRIM
PITCH/DELAY		MODE	PITCH	FINE	PITCH HI CUT		PITCH MIX
		DELAY TIME	DELAY TIME	DELAY TIME	FEED BACK	DLY HI DAMP	DELAY MIX
CHORUS/FLANGER		MODE	DELAY TIME	SPEED	DEPTH	FEEDBACK	MIX
REVERB		MODE	REVERB TIME	HIGH DAMP			MIX
UTILITY		TUNER CALIB	MIDI CH	EXT. CTRL	AMP SIM	NR LEVEL	LEVEL

BANK NO	PROG NO	A4G PROG					
COMPRESSOR		SENS	ATTACK				LEVEL
DIST/OD		MODE	GAIN	TONE	EQ LATCH		LEVEL
3 BAND EQ		BASS GAIN	MID FREQ	MID GAIN	HIGH FREQ	HIGH GAIN	TRIM
PITCH/DELAY		MODE	PITCH	FINE	PITCH HI CUT		PITCH MIX
		DELAY TIME	DELAY TIME	DELAY TIME	FEED BACK	DLY HI DAMP	DELAY MIX
CHORUS/FLANGER		MODE	DELAY TIME	SPEED	DEPTH	FEEDBACK	MIX
REVERB		MODE	REVERB TIME	HIGH DAMP			MIX
UTILITY		TUNER CALIB	MIDI CH	EXT. CTRL	AMP SIM	NR LEVEL	LEVEL

# PROGRAM LIST

1

2

3

4

5

6

<b>Bank 1</b> /→ Amp	Thrash Man <span style="border: 1px solid black; padding: 2px;">11</span> <small>Dist Mode 7</small>	Valve Screamer <span style="border: 1px solid black; padding: 2px;">12</span> <small>Dist Mode 2</small>	Semi Clean 1 <span style="border: 1px solid black; padding: 2px;">13</span> <small>Dist Mode 2</small>	Echo Delay <span style="border: 1px solid black; padding: 2px;">14</span> <small>Dist Mode 2</small>	Andy S <span style="border: 1px solid black; padding: 2px;">15</span> <small>Dist Mode 2</small>	Cloud Five <span style="border: 1px solid black; padding: 2px;">16</span> <small>Dist Mode 2</small>
-------------------------	---------------------------------------------------------------------------------------------------------------	-------------------------------------------------------------------------------------------------------------------	-----------------------------------------------------------------------------------------------------------------	---------------------------------------------------------------------------------------------------------------	--------------------------------------------------------------------------------------------------------	---------------------------------------------------------------------------------------------------------------

<b>Bank 2</b> /→ Amp	Gain Meister <span style="border: 1px solid black; padding: 2px;">21</span> <small>Dist Mode 4</small>	Wet Overdrive <span style="border: 1px solid black; padding: 2px;">22</span> <small>Dist Mode 1</small>	Semi Clean 2 <span style="border: 1px solid black; padding: 2px;">23</span> <small>Dist Mode 1</small>	Doppler Delay <span style="border: 1px solid black; padding: 2px;">24</span> <small>Dist Mode 2</small>	LA Chorus <span style="border: 1px solid black; padding: 2px;">25</span> <small>Dist Mode 5</small>	Octave Driver <span style="border: 1px solid black; padding: 2px;">26</span> <small>Dist Mode 2</small>
-------------------------	-----------------------------------------------------------------------------------------------------------------	------------------------------------------------------------------------------------------------------------------	-----------------------------------------------------------------------------------------------------------------	------------------------------------------------------------------------------------------------------------------	--------------------------------------------------------------------------------------------------------------	------------------------------------------------------------------------------------------------------------------

<b>Bank 3</b> /→ Amp	Super Distortion <span style="border: 1px solid black; padding: 2px;">31</span> <small>Dist Mode 5</small>	Tube Overdrive <span style="border: 1px solid black; padding: 2px;">32</span> <small>Dist Mode 2</small>	Semi Clean 3 <span style="border: 1px solid black; padding: 2px;">33</span> <small>Dist Mode 2</small>	Slap Delay <span style="border: 1px solid black; padding: 2px;">34</span> <small>Dist Mode 2</small>	NY Flange <span style="border: 1px solid black; padding: 2px;">35</span> <small>Dist Mode 4</small>	Pitch Synth <span style="border: 1px solid black; padding: 2px;">36</span> <small>Dist Mode 1</small>
-------------------------	---------------------------------------------------------------------------------------------------------------------	-------------------------------------------------------------------------------------------------------------------	-----------------------------------------------------------------------------------------------------------------	---------------------------------------------------------------------------------------------------------------	--------------------------------------------------------------------------------------------------------------	----------------------------------------------------------------------------------------------------------------

<b>Bank 4</b> /→ Amp	George Tone <span style="border: 1px solid black; padding: 2px;">41</span> <small>Dist Mode 5</small>	Squeeze Drive <span style="border: 1px solid black; padding: 2px;">42</span> <small>Dist Mode 1</small>	Edge <span style="border: 1px solid black; padding: 2px;">43</span> <small>Dist Mode 2</small>	Analog Delay <span style="border: 1px solid black; padding: 2px;">44</span> <small>Dist Mode 2</small>	Univibe <span style="border: 1px solid black; padding: 2px;">45</span> <small>Dist Mode 1</small>	Detune Wash <span style="border: 1px solid black; padding: 2px;">46</span> <small>Dist Mode 2</small>
-------------------------	----------------------------------------------------------------------------------------------------------------	------------------------------------------------------------------------------------------------------------------	------------------------------------------------------------------------------------------------------	-----------------------------------------------------------------------------------------------------------------	---------------------------------------------------------------------------------------------------------	----------------------------------------------------------------------------------------------------------------

<b>Bank 5</b> /→ Line	Line Distortion <span style="border: 1px solid black; padding: 2px;">51</span> <small>Dist Mode 7</small>	Line Overdrive <span style="border: 1px solid black; padding: 2px;">52</span> <small>Dist Mode 2</small>	Line SemiClean <span style="border: 1px solid black; padding: 2px;">53</span> <small>Dist Mode 3</small>	Line Delay <span style="border: 1px solid black; padding: 2px;">54</span> <small>Dist Mode 1</small>	Bright Funk <span style="border: 1px solid black; padding: 2px;">55</span> <small>Dist Mode 2</small>	Pitch Wash <span style="border: 1px solid black; padding: 2px;">56</span> <small>Dist Mode 1</small>
--------------------------	--------------------------------------------------------------------------------------------------------------------	-------------------------------------------------------------------------------------------------------------------	-------------------------------------------------------------------------------------------------------------------	---------------------------------------------------------------------------------------------------------------	----------------------------------------------------------------------------------------------------------------	---------------------------------------------------------------------------------------------------------------

★ At the time of factory shipping, a program and a preset area are included in the user area.

# SPECIFICATIONS AND OPTIONS

- Internal Effects  
COMPRESSOR, DISTORTION/OVERDRIVE, 3-BAND EQ, PITCH/DELAY, CHORUS/FLANGER, REVERB, AMP SIMULATION, NOISE REDUCTION
  - Programs  
Preset: 30  
User programmable: 30
  - Front Panel  
Volume: INPUT VOLUME, PARAMETER EDITORS, OUTPUT VOLUME  
Keys/Switches: BANK UP SWITCH, WRITE KEY, USER/PRESET KEY, BYPASS•TUNE SWITCH, EFCT/PROG SWITCHES, MODE SELECT SWITCH, MODE (Effect) SELECT KEYS(UP, DOWN)  
Display: BANK/VALUE Display: 8 segment LED x 2  
Dot type LEDs: EFCT/PROG LEDs, MODE LEDs, Peak Indicator
  - Rear Panel  
Power Switches  
DC9V Jack  
INPUT Terminal  
OUTPUT Terminal (2) (R, L/MONO)  
PHONES Jack  
VOLUME PEDAL Jack  
EXTERNAL CONTROL OUTPUT Terminal (2) (1,2)  
MIDI Terminal (2) (IN, OUT)
  - Sampling Frequency: 48 kHz
  - Dynamic Range: 90dB or more (IHF – A, when bypassing)
  - TUNER:  
Measurement Range: A $\phi$ -C7  
Measurement Accuracy:  $\pm$ 0.5 cent.  
Power Supply: DC9V.
  - Power Consumption: 350mA
  - Maximum Input Level/Impedance: +7dBu/1M $\Omega$
  - Maximum Output Level/Impedance: +7.5dBu/1k  $\Omega$
  - Dimensions: 498 (W) x 227.5 (D) x 48.7 (H) mm
  - Weight: 2.2kg
  - Options: Volume Pedal KVP – 001
- ★ Specifications, operations, and appearance are subject to change without notice.

**N O T I C E**

KORG products are manufactured under strict specifications and voltages required by each country. These products are warranted by the KORG distributor for each separate country only. Any KORG product sold without a warranty card or not carrying a serial number disqualifies the product from the manufacturer's warranty and liability. This requirement is for your own protection and safety.

**KORG**

**KORG INC.**

15 - 12, Shimotakaido 1 - chome, Suginami - ku, Tokyo, Japan.